



WHAT YOU NEED TO KNOW:

STEERING, SUSPENSION AND WHEEL END DIAGNOSTIC TIPS

Cars, CUVs & Minivans

Multilink

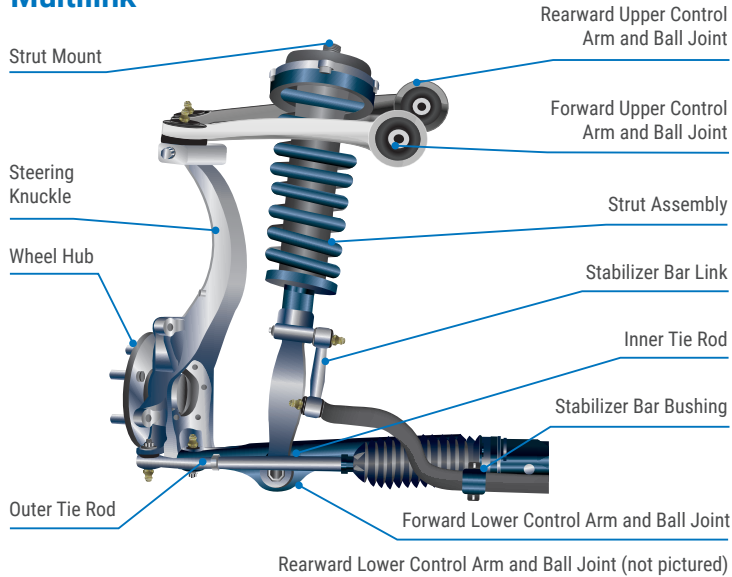

MacPherson

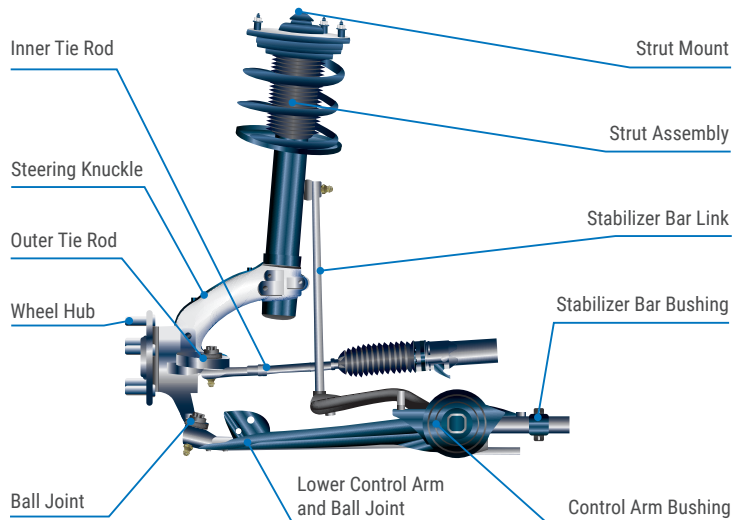

**Routine inspection can prevent major repairs.
Here are some common issues and what to look for:**



Front End Looseness

- Upper and Lower Ball Joints
- Control Arm Bushings
- Inner and Outer Tie Rods
- Wheel Bearing
- Wheel Hub
- CV Shaft



Front End Knock

- Upper and Lower Ball Joints
- Control Arm Bushings
- Inner and Outer Tie Rods
- Stabilizer Bar Links
- Stabilizer Bar Bushings
- Strut Assembly
- Wheel Bearing
- Wheel Hub
- CV Shaft



Steering Wheel Looseness & Vibration

- Upper and Lower Ball Joints
- Control Arm Bushings
- Inner and Outer Tie Rods
- Stabilizer Bar Links
- Stabilizer Bar Bushings
- Strut Assembly
- Wheel Bearing
- Wheel Hub
- CV Shaft



Vehicle Pulls to Left or Right

- Upper and Lower Ball Joints
- Control Arm Bushings
- Outer Tie Rods
- Strut Mount
- Steering Rack
- Incorrect Tire Inflation
- Uneven Tire Wear
- Check Alignment



Body Roll when Turning

- Stabilizer Bar Links
- Stabilizer Bar Bushings



Excessive Bounce

- Strut Assembly



Uneven and Premature Tire Wear

- Upper and Lower Ball Joints
- Control Arm Bushings
- Inner and Outer Tie Rods
- Strut Assembly
- Incorrect Tire Inflation
- Check Alignment



ABS Light or Rumble Sound

- Wheel Bearings
- Wheel Hubs



WHAT YOU NEED TO KNOW:

STEERING, SUSPENSION AND WHEEL END DIAGNOSTIC TIPS

Trucks & Full-Size SUVs

Double Wishbone

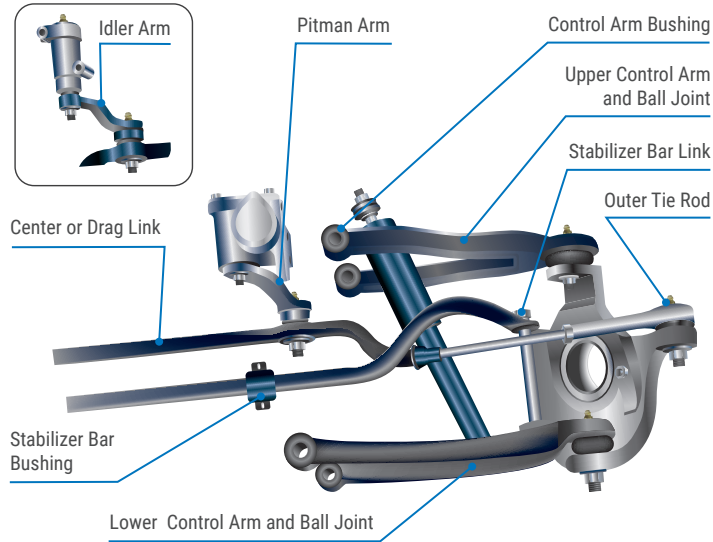

Solid Axle

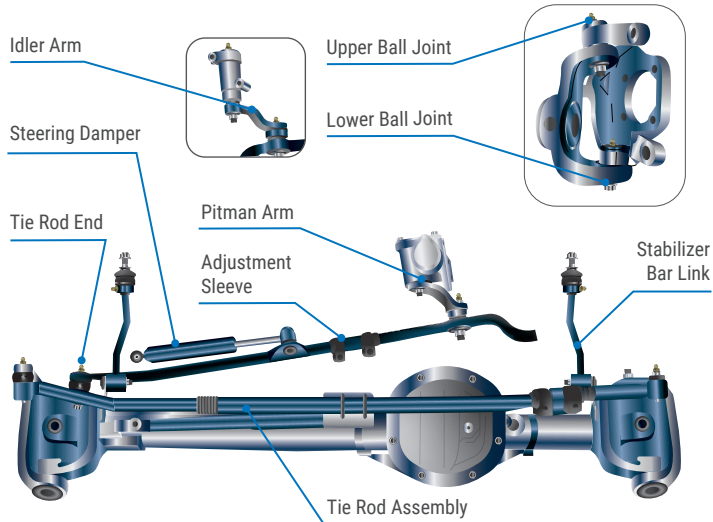

Routine inspection can prevent major repairs.
Here are some common issues and what to look for:



Front End Looseness

- Upper and Lower Ball Joints
- Track Bar Ball Joint
- Control Arm Bushings
- Outer Tie Rods
- Center/Drag Link
- Idler/Pitman Arm



Front End Knock

- Upper and Lower Ball Joints
- Track Bar Ball Joint
- Control Arm Bushings
- Inner and Outer Tie Rods
- Center/Drag Link
- Idler/Pitman Arm
- Stabilizer Bar Links
- Stabilizer Bar Bushings
- Strut Assembly/Shocks



Steering Wheel Looseness & Vibration

- Upper and Lower Ball Joints
- Track Bar Ball Joint
- Control Arm Bushings
- Inner and Outer Tie Rods
- Center/Drag Link
- Idler/Pitman Arm
- Steering Stabilizer



Vehicle Pulls to Left or Right

- Upper and Lower Ball Joints
- Track Bar Ball Joint
- Control Arm Bushings
- Inner and Outer Tie Rods
- Center/Drag Link
- Idler/Pitman Arm
- Steering Damper
- Uneven Tire Wear
- Incorrect Tire Inflation
- Check Alignment



Body Roll when Turning

- Stabilizer Bar Links
- Stabilizer Bar Bushings



Excessive Bounce

- Strut Assembly/Shocks



Uneven and Premature Tire Wear

- Upper and Lower Ball Joints
- Track Bar Ball Joint
- Control Arm Bushings
- Inner and Outer Tie Rods
- Center/Drag Link
- Idler/Pitman Arm
- Steering Stabilizer
- Incorrect Tire Inflation
- Check Alignment



ABS Light or Rumble Sound

- Wheel Bearings
- Wheel Hubs