



1999-2005 Ford F-Series Thrust Washer Orientation

Brand	BXT	Product	Wheel Hub Assembly	Date	May 2020
Part Number(s)	H515020/H515021/H515056/H515057/H515075/H515076/H515077				

Issue: Correct order of thrust washers

When removing or replacing the front wheel hub for the below listed applications, it is important to correctly place the three thrust washers in proper order, prior to installing the retention clip.

Failure to correctly order the washers may lead to premature wear of the wheel hub assembly.

Solution

1. Visually inspect the three washers. Replace if worn or damaged.
2. Ensure the non-metallic washer is positioned in between the metal washers. The correct order is metal (round) – non-metal (hex)-metal (round).
3. Install retention clip and ensure that it snaps into the retention groove.

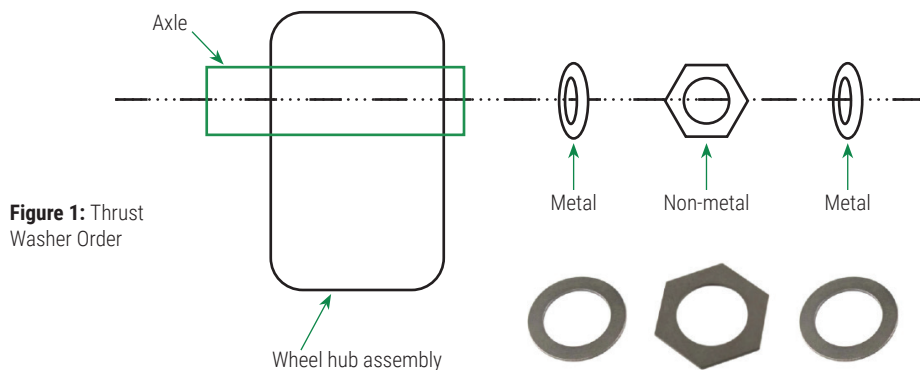

Figure 1: Thrust Washer Order

APPLICATIONS		
FORD	1999-2005	F-250
		F-350
		F-450

