



## Correct Dust Boot Installation Procedure – 2014-1988 Honda & Acura Front and Rear Upper Ball Joint

Brand	Supreme	Product	Ball Joint	Date	June 2021
<b>Part Number(s)</b>	MK90469/MK90336/MK80199				

To ensure optimal part service life and prevent contaminant ingress, it is important to follow the correct dust boot installation procedure when completing a ball joint replacement using the below noted part number(s):

**Part Number(s)**

- MK90649
- MK90336
- MK80199

For a successful repair outcome, adhere to the following:

- Ball joint dust boot must be installed after pressing-in ball joint to control arm.
- Place dust boot over ball stud and confirm that the dust boot is completely fitted over machined ball joint housing groove.
- Using the appropriate circlip tool, expand circlip to fit over dust boot. Circlip provides a positive boot seal and additional retention.
- Position circlip over dust boot and onto housing groove. Verify secure placement. **See Figure 1.**

The above steps are illustrated in **Figure 2.**



**Figure 1.** Circlip is securely fitted to boot. Both circlip and boot are properly located onto machined housing groove.

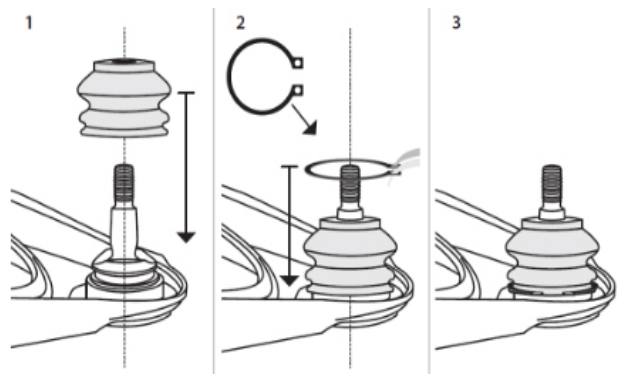

**Figure 2.** Illustration denoting correct dust boot installation procedure.

Always ensure to refer to the factory service manual for correct diagnostic procedures, component removal and installation methods and fastening torque values and procedures where applicable.

