



Correct Installation Orientation: 2010-1999 GM 1500-2500-3500 Truck Front Lower Ball Joint

Brand	TTX	Product	Ball Joint	Date	November 2022
Part Number(s)	TXK6693				

To ensure adequate access to the grease fitting, the below noted ball joint must be pressed-in using the correct orientation.

Part Number:

TXK6693

For a successful repair outcome, adhere to the following:

- Before installation of ball joint, ensure all mating surfaces are clear of rust, debris and burrs.
- Verify press-in diameters and stud tolerances, including on steering knuckle side. Inspect mating surfaces for cracks, deformation and or an out of round condition. Replace all damaged or out-of-specification mating components.
- The ball joint must be installed with the grease fitting in alignment to channel groove on front lower control arm. **See Figure 1.**
- Before press-in, it is recommended to create an index mark on both the control arm and ball joint housing using a suitable implement, such as a grease pencil. This will assist in attaining correct orientation during press-in.

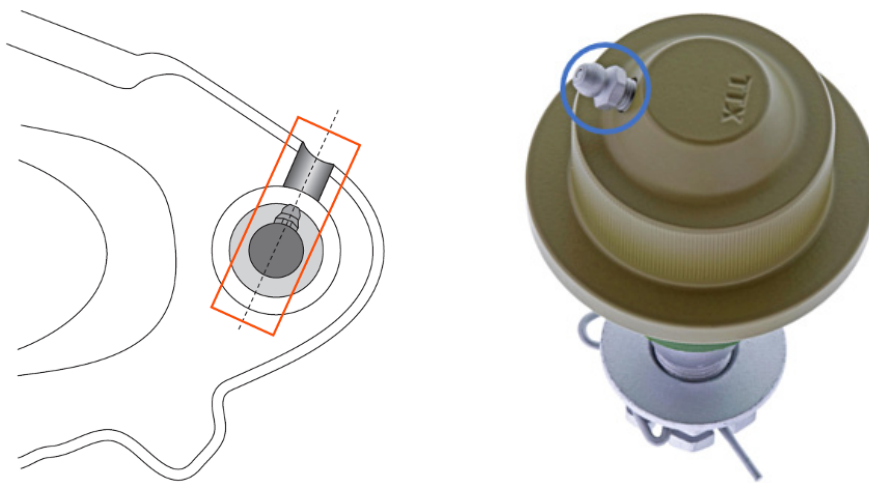

Figure 1. To ensure adequate clearance between components and accessibility for future relubrication service, ball joint must be installed with grease fitting in alignment to channel groove on front lower control arm

Always ensure to refer to the factory service manual for correct diagnostic procedures, component removal and installation methods and fastening torque values and procedures where applicable. Only use a calibrated torque wrench for final fastening.

