



Correct Installation Orientation: 2022-2014 RAM 2500 and 3500 Front Lower Ball Joint

Brand	TTX	Product	Ball Joint	Date	September 2022
Part Number(s)	TXMS25532				

To ensure adequate access to the grease fitting for relubrication service, the below noted ball joint must be pressed-in using the correct orientation.

Part Number
TXMS25332

For a successful repair outcome, adhere to the following:

- Before installation of ball joint, ensure all mating surfaces are clear of rust, debris and burrs.
- Verify press-in diameters and stud tolerances, including on steering knuckle side. Inspect mating surfaces for cracks, deformation and or an out of round condition. Replace all damaged or out-of-specification mating components.
- Correct orientation is achieved when grease fitting is located approximately 45° towards centerline of vehicle. Grease fitting must also be positioned towards front of vehicle. **See Figure 1.**
- Before press-in, it is recommended to create an index mark on both axle and ball joint housing using a suitable implement, such as a grease pencil. This will assist in attaining correct orientation during press-in.

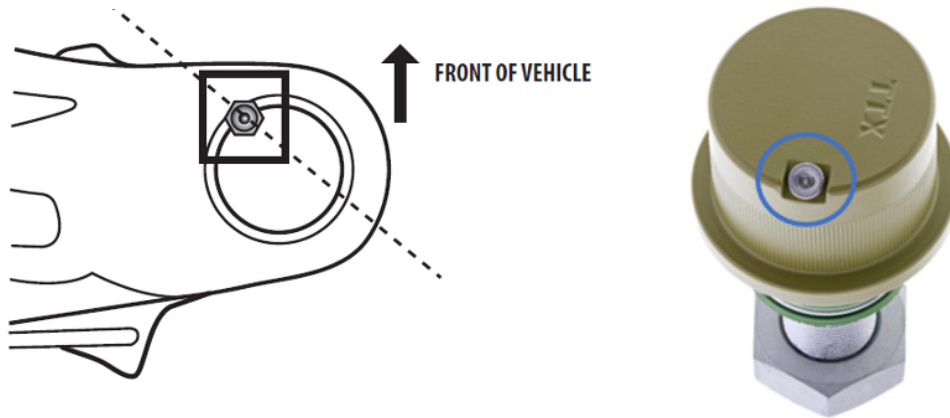

Figure 1. To ensure adequate clearance between components for relubrication service, ball joint must be installed with grease fitting positioned approximately 45° towards centerline of vehicle.

Always ensure to refer to the factory service manual for correct diagnostic procedures, component removal and installation methods and fastening torque values and procedures where applicable. Only use a calibrated torque wrench for final fastening.

