



Ford Thunderbird, Lincoln LS and Jaguar S-Type Front Knuckle and Lower Ball Joint

Brand	Supreme	Product	Ball Joint	Date	June 2020
Part Number(s)	MS40501-MS40502/MS40503-MS40504				

Due to production date variances, the lower ball joint on the identified vehicles may feature either a M14 or M16 nut/stud.

It is critical to note that due to these variations, the proper torque specification must be followed to eliminate possibility of premature component failure or ball joint separation from the lower control arm.

Application	Nut/Stud	PN#	TQ Value for Ball Joint Nut
2002 Ford Thunderbird (to 3/11/2002)	M14	MS40501-MS40502	111LB-FT/150N·M
2000-2001 Jaguar S-Type	M14	MS40501-MS40502	111LB-FT/150N·M
2000-2002 Lincoln LS (to 3/11/2002)	M14	MS40501-MS40502	111LB-FT/150N·M

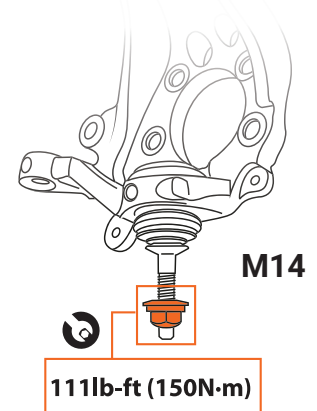

Application	Nut/Stud	PN#	TQ Value for Ball Joint Nut
2002-2005 Ford Thunderbird (from 3/12/2002)	M16	MS40503-MS40504	148LB-FT/201N·M
2002-2006 Lincoln LS (from 3/12/2002)	M16	MS40503-MS40504	148LB-FT/201N·M

