



Major Design Improvement: 2015-2007 GM Compact SUV Rear Stabilizer Bar Links

Brand	Supreme	Product	Stabilizer Bar Link	Date	July 2021
Part Number(s)	MS50839				

The OEM (PN#: 15926031) and other OE-style rear stabilizer bar links for the application(s) below utilize a non-greaseable plastic bearing, 2-piece hollow ball pin and the original lightweight plastic body.

Application(s)

- 2015-2012 Chevrolet Captiva Sport
- 2009-2007 Chevrolet Equinox
- 2009-2007 Pontiac Torrent
- 2010-2008 Saturn Vue
- 2009-2007 Suzuki XL-7

Mevotech Supreme rear stabilizer bar link MS50839 is engineered with an improved solid steel design. This adds rigidity and strength to the assembly and reduces flex and cycling while the vehicle is in motion. Additionally, the MS50839 is characterized by greaseable self-lubricating upper and lower sintered metal bearings for increased part service life and a solid 1-piece ball pin that increases bearing contact for optimized pressure distribution. New hardware is included for a complete install. **See Figure 1.**

MS50839

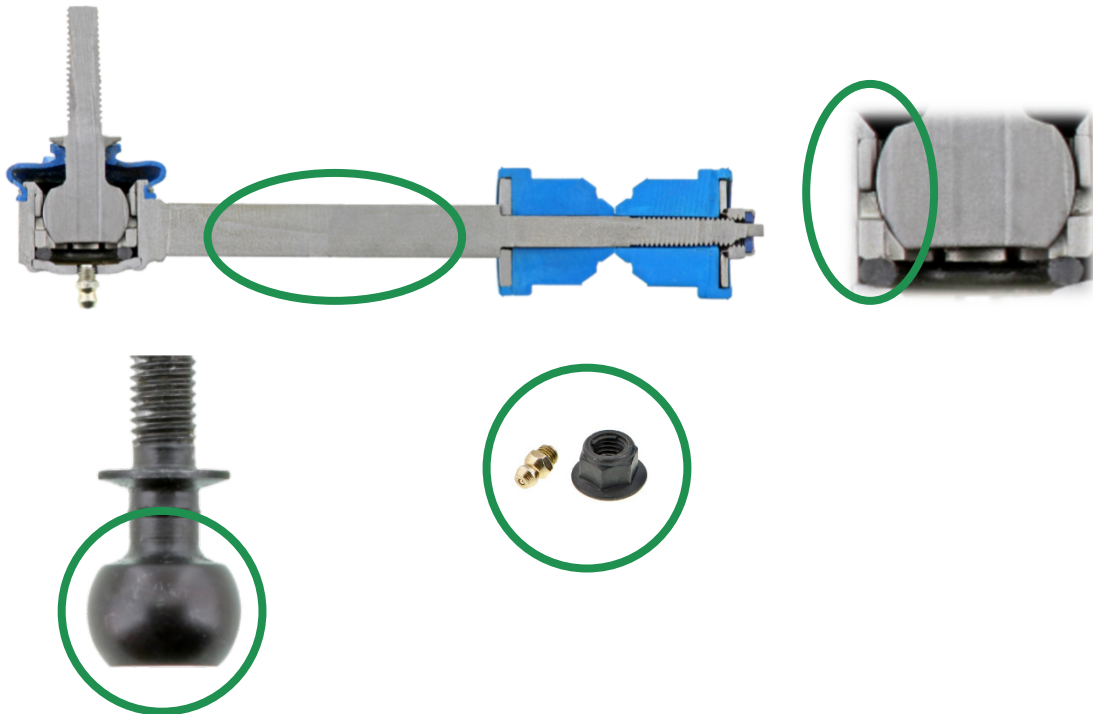

OEM

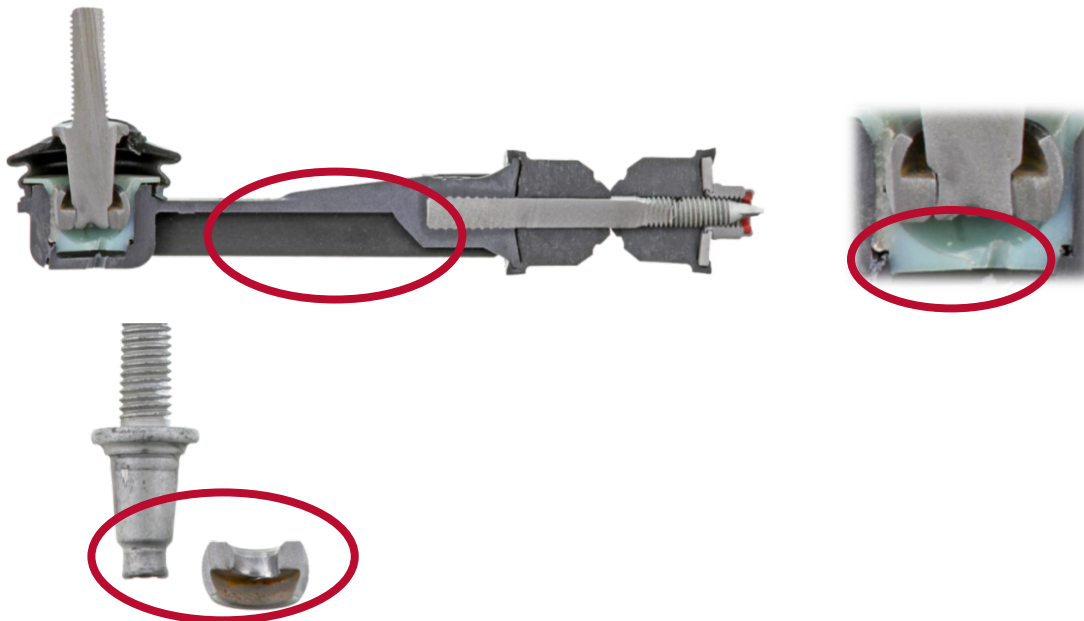

Figure 1. Mevotech Supreme rear stabilizer link MS50839 with solid steel design featuring greaseable self-lubricating sintered upper and lower metal bearings, 1-piece solid ball pin and included hardware (top) vs OEM plastic body, sealed plastic bearing and 2-piece ball pin (bottom)